

INFORMAÇÕES TÉCNICAS



Sistema para 2 portas



Fechamento e abertura amortizados

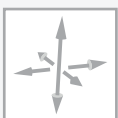

Regulagem tridimensional



Capacidade de carga por porta 10kg



Espessura da porta mín. de 16mm máx. de 30mm

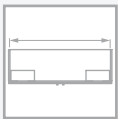

Largura do trilho mín. 988mm máx. 1627mm



Largura das portas mín. 510mm máx. 828mm

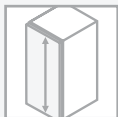

Altura máxima das portas 800mm



Chave allen 3



Chave de boca 10

INSTRUÇÕES DE MONTAGEM



Animação de montagem disponível no site

MEDIDAS DE INSTALAÇÃO

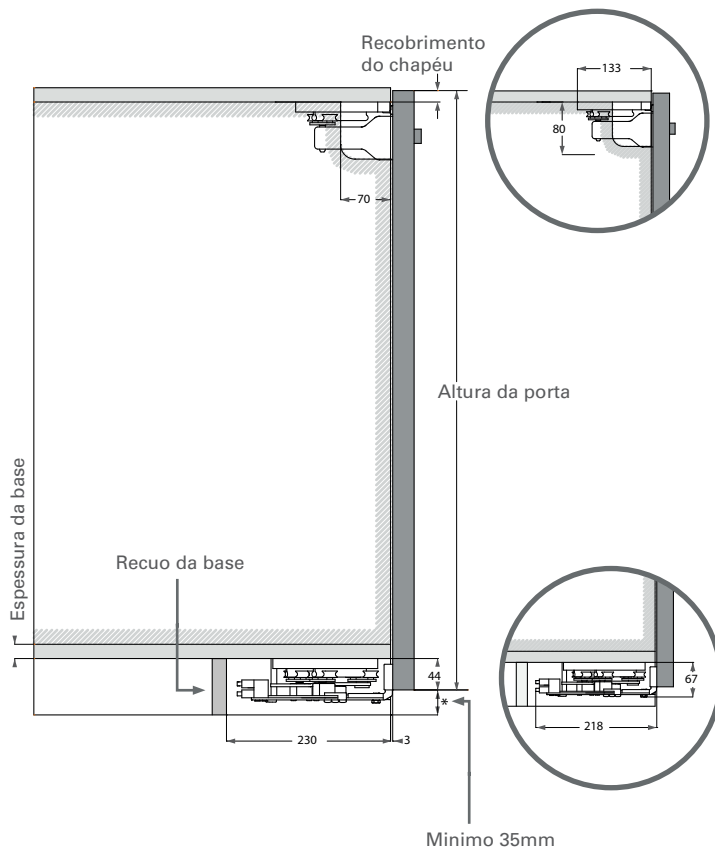
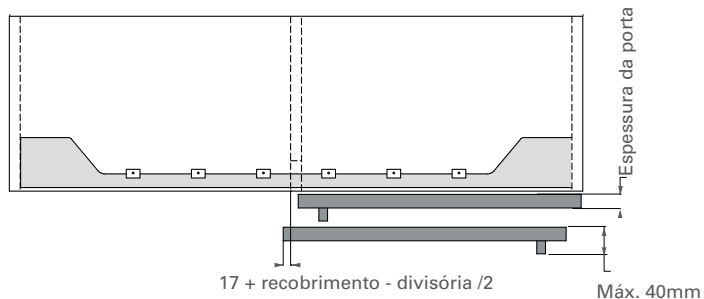
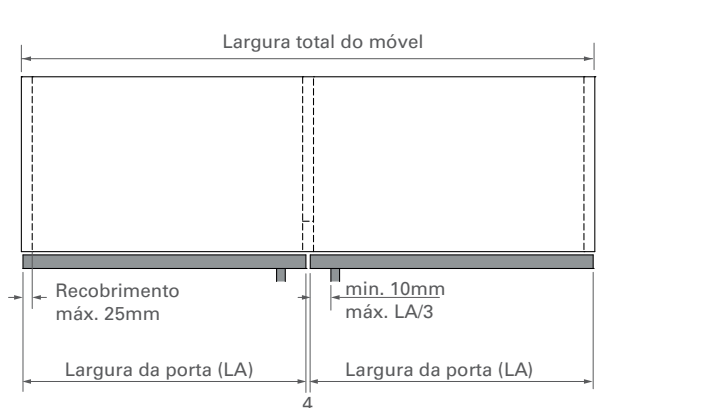

Altura da porta = Altura interna + Espessura da base + 44 + recobrimento do chapéu

> COMPONENTES DO SISTEMA



Não cortar/alterar os trilhos

Trilho superior

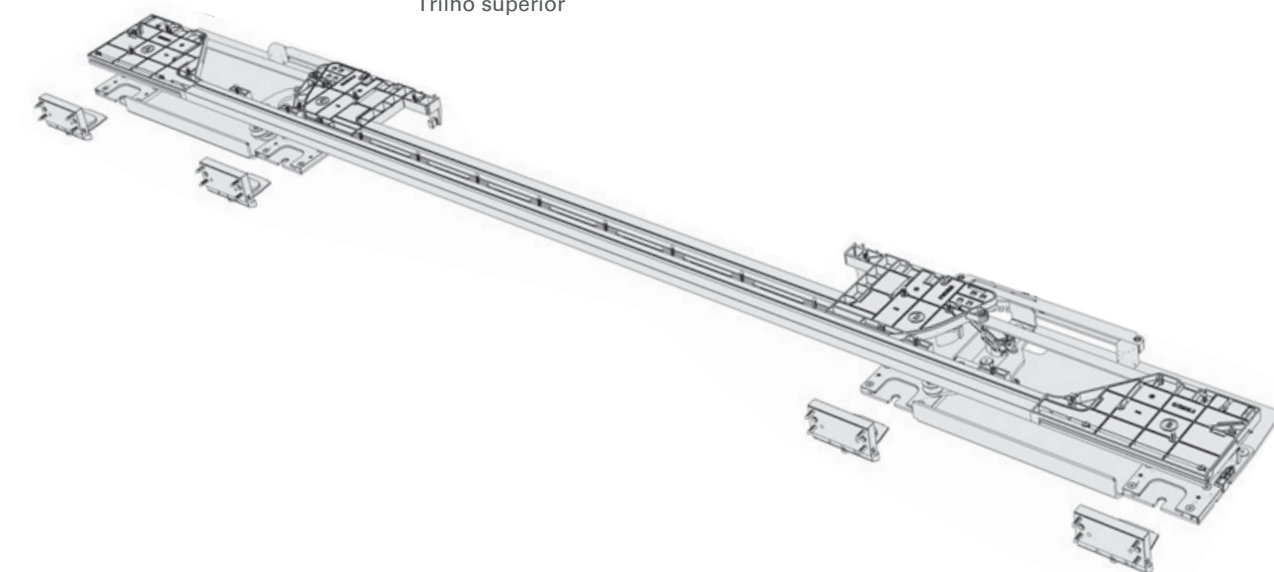

Trilho inferior

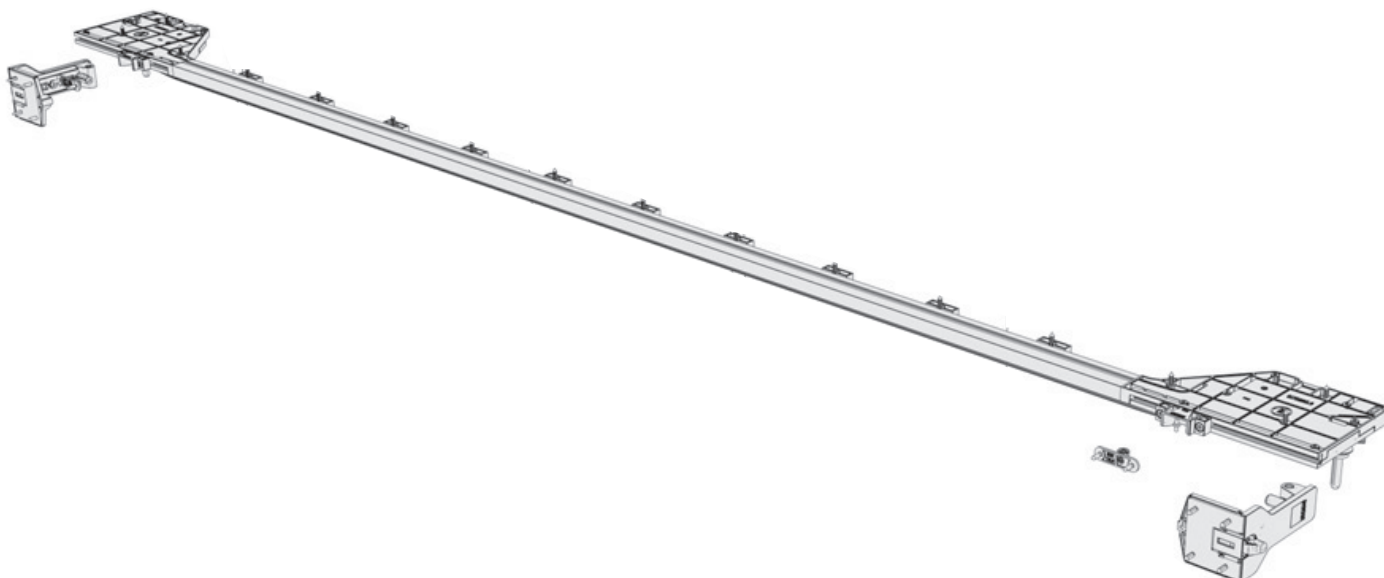

CÓDIGO	DESCRIÇÃO
83020110087	Coplanar S10 Flex inferior montado para largura interna do móvel de 988mm até 1115mm 2 portas com 10kg cada
83020110088	Coplanar S10 Flex inferior montado para largura interna do móvel de 1116mm até 1371mm 2 portas com 10kg cada
83020110089	Coplanar S10 Flex inferior montado para largura interna do móvel de 1372mm até 1627mm 2 portas com 10kg cada