

## INFORMAÇÕES TÉCNICAS



Largura do móvel  
mín. 800mm  
máx. 1000mm



Largura da porta  
mín. 450mm  
máx. 600mm



Profundidade do móvel  
mín. 490mm



Altura do móvel  
mín. 650mm  
mín. 1350mm



Capacidade de carga por cesto 25kg



Cromado



Componente em aço

## INSTRUÇÕES DE MONTAGEM



Animação de montagem disponível no site

## MEDIDAS DE INSTALAÇÃO

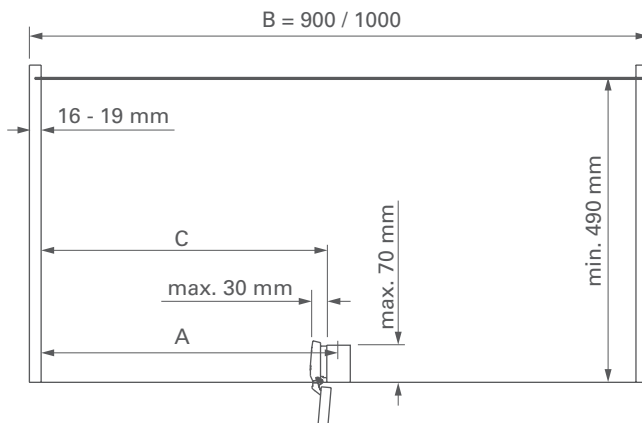

## DIMENSÕES DO ARMÁRIO

A	B (mín.)	C
900	900	mín. 411
1000	1000	mín. 461
1000	1000	mín. 561

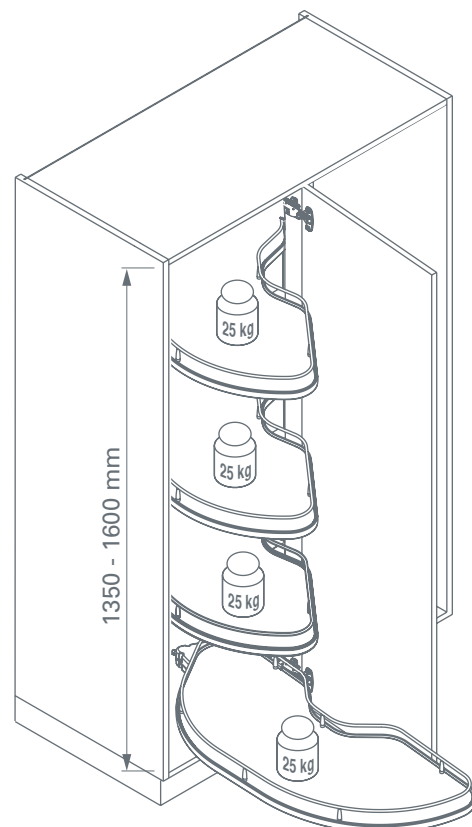
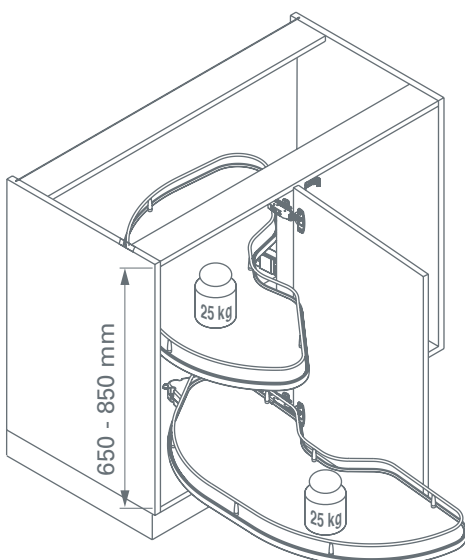

> COMPONENTES

CESTO

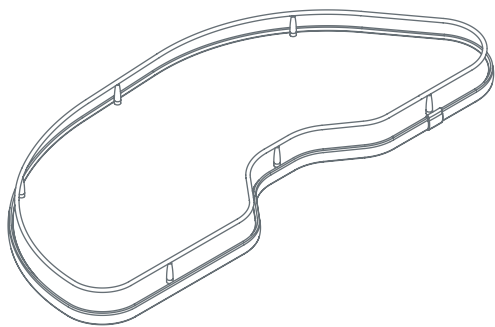

Aberturas

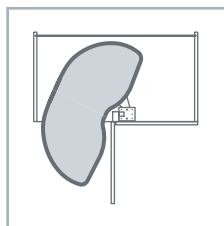

Saída para a esquerda

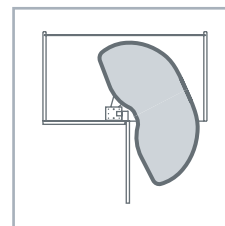

Saída para a direita

ESTRUTURA

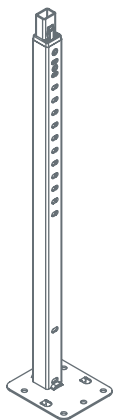

CÓDIGO	DESCRIÇÃO
83250410004	Cornertone Maxx direito com 02 cestos premea cromado com railing para módulo de 900mm com porta de 450mm
83250410005	Cornertone Maxx esquerdo com 02 cestos premea cromado com railing para módulo de 900mm com porta de 450mm
83250410006	Cornertone Maxx direito com 02 cestos premea cromado com railing para módulo de 1000mm com porta de 500mm
83250410007	Cornertone Maxx esquerdo com 02 cestos premea cromado com railing para módulo de 1000mm com porta de 500mm
83250410008	Cornertone Maxx direito com 02 cestos premea cromado com railing para módulo de 1000mm com porta de 600mm
83250410009	Cornertone Maxx esquerdo com 02 cestos premea cromado com railing para módulo de 1000mm com porta de 600mm

\*Cornertone Maxx com 04 cestos sob consulta.