

GIVI MOBILI ACESSÓRIOS PARA MÓVEIS LTDA.
Rua João Bettega, 4.800, Módulo V - CEP 81350-000 - CIC - Curitiba - PR
Fone: (41) 3906-8080 FAX: (41) 3906-8008
www.givimobili.com.br

DOBRADIÇA AIR SMOVE



Furadeira/
Parafusadeira

PH 2
Chave
Philips nº 2

Trena

Componentes para porta de alumínio



Par de dobradiças
Air



Conjunto esquadros
de fixação

Componentes para porta de madeira



Par de dobradiças
Air

1 Espaço para abertura das portas

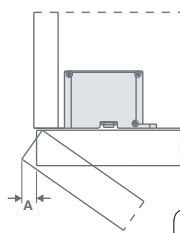

T=	18	20	22	24	26	28	30	32
K=3	A= 0	0.2	0.5	0.8	2.3	4.9	7.5	10.0
K=4	A= 0	0.2	0.4	0.8	1.3	3.9	6.5	9.0
K=5	A= 0	0.2	0.4	0.8	1.3	2.9	5.5	8.0
K=6	A= 0	0.2	0.4	0.8	1.2	1.9	4.5	7.0

Caso seja feito alguma modelagem na portas pode haver redução no valor de "A".



2 Entrada das portas

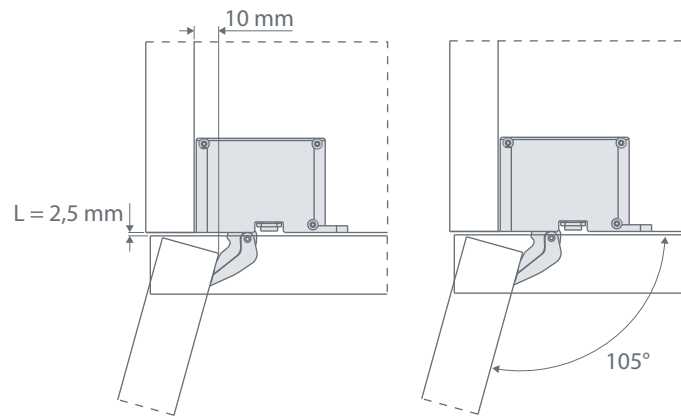

Entrada da porta em relação à lateral com sua máxima abertura. O valor informado é com K=3 e cobertura da porta sobre a lateral de 19 mm.



3 Usinagem para perfil de alumínio

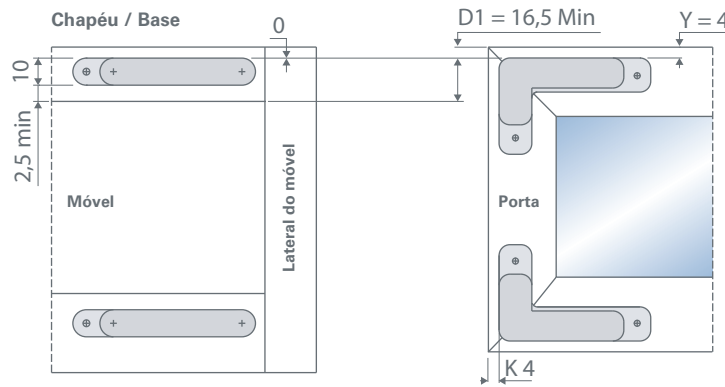

Lateral

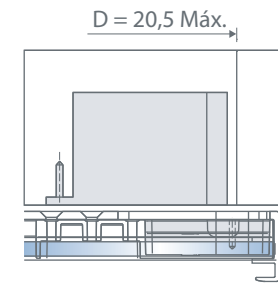

4 Usinagem para a instalação da dobradiça para perfil de alumínio

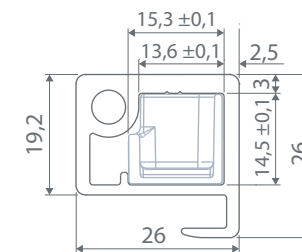
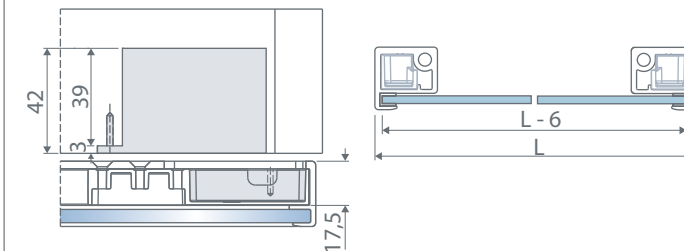
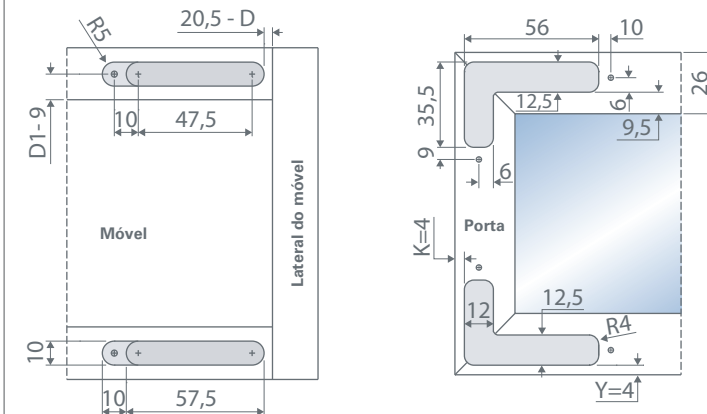

5 Usinagem para porta de madeira

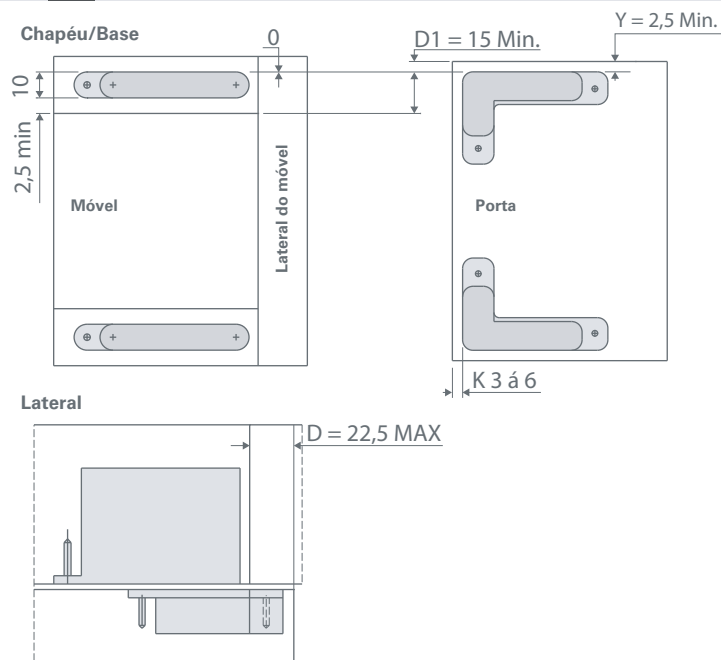

6 Usinagem para a instalação da dobradiça para porta de madeira

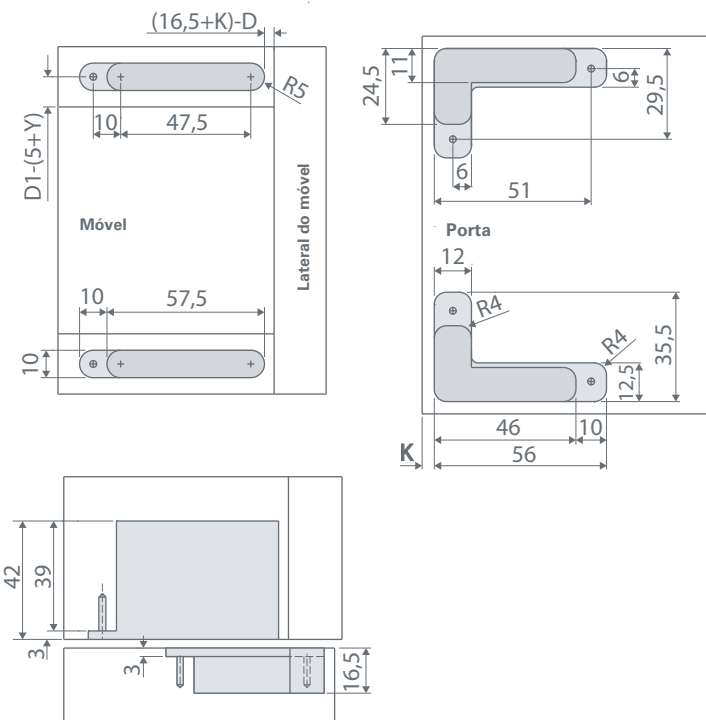

7 Montagem do quadro de alumínio

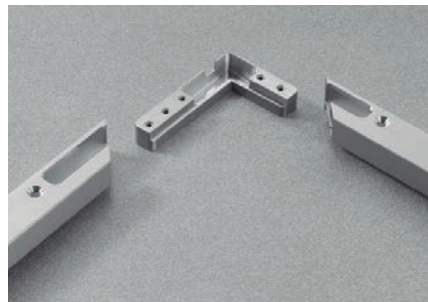

Com os perfis usinados e as portas cortadas em ângulo de 45° encaixe os esquadros conforme imagem.

Para fixar os perfis no esquadro utilize os parafusos.



Encaixe a dobradiça no esquadro.



Para fixar a dobradiça no esquadro utilize os parafusos.

Os perfis que compõem a porta são cortados na medida desejada, a 45° e com as respectivas usinagens para a aplicação das dobradiças.



8 Regulagens

Regulagem Lateral de +2 a -2

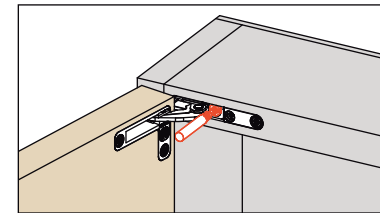
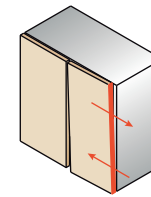

Regulagem Frontal de +2 a -0,5

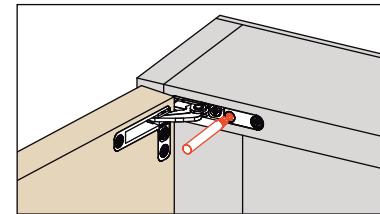
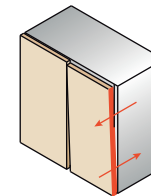

Regulagem Vertical de +1,5 a -1,5

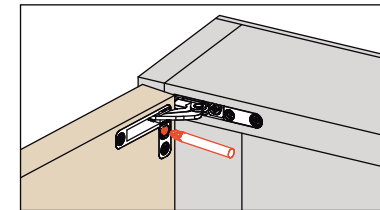
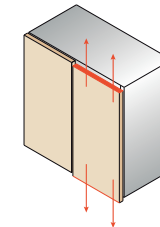

Givi